

REVISIONS			
REV.	DESCRIPTION	DATE	APPROVED
A	INITIAL RELEASE	28-07-2021	GUTTADAURO

1. CONSTRUCTION:

CONDUCTOR: 23 AWG SOLID BARE COPPER, DIA. (±0.005mm) 0.57

INSULATION: HIGH DENSITY POLYETHYLENE
 AVERAGE THICKNESS (mm) 0.195
 MIN. POINT THICKNESS (mm) 0.179
 INSULATION DIA.(±0.01mm) 0.96
 TWISTED PAIR DIA.(±0.02mm) 1.92

PAIRS: COLOR CODED SINGLES TWISTED INTO PAIRS

CABLE: (4) TWISTED PAIRS TWISTED TOGETHER TO FORM A CABLE CORE
 (4PAIRS CAT5E UTP CABLE SPECS)
 FILLER- FR-PE SPLINE

JACKET: CMP RATED PVC
 AVERAGE THICKNESS (mm) 0.55
 MIN. POINT THICKNESS (mm) 0.50
 OUTER DIA. (±0.1mm) 6.00
 OVERALL CABLE DIAMETER RIP CORD (NYLON)

2. PHYSICAL PROPERTIES:
 TEMPERATURE RATING MAX. 75°C
 TEMPERATURE RATING MIN. -20°C

3. AGENCY APPROVALS:
 ETL LISTED

4. APPLICATION:
 MEETS TIA568 C.2 CHANNEL REQUIREMENTS AT 53 METERS. 6.5 METERS OF PATCH CABLE WITH A 90 METERS PERMANENT LINK (96.5 METER CHANNEL) OR 10 METERS OF PATCH CABLE WITH A 84 METER PERMANENT LINK (94 METER CHANNEL)

5. ELECTRICAL CHARACTERISTICS: (FOR 100m OF CABLE)
 PAIR-TO-GROUND CAPACITANCE UNBALANCE ≤330 pF/100m
 MAX. CONDUCTOR DC RESISTANCE 20°C 93.8Ω/km
 IMPEDANCE 100±15Ω 1-250 MHz
 RETURN LOSS
 1 ≤ f ≤ 10 MHz 20 + 5 LOG (F) dB MIN
 10 ≤ f ≤ 20 MHz 25 dB MIN
 20 ≤ f ≤ 100 MHz 22 - 2 LOG (F/20) dB MIN

6. PACKAGING:
 CABLE SHIPPED ON A PULL BOX (305m / 1000ft)

COLOR CODE:

- A. BLUE,WHITE/BLUE
- B. ORANGE,WHITE/ORANGE
- C. GREEN,WHITE/GREEN
- D. BROWN,WHITE/BROWN

CROSS-SECTIONAL VIEW

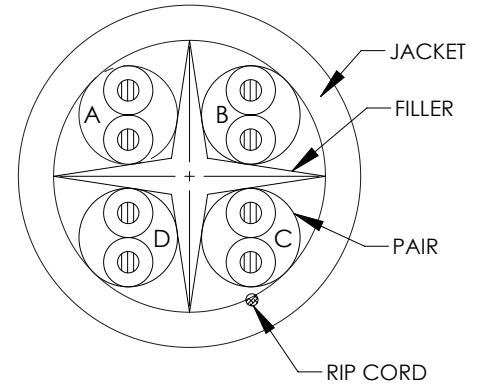

1000 FEET OF CONTINUOUS LENGTH BULK CABLE

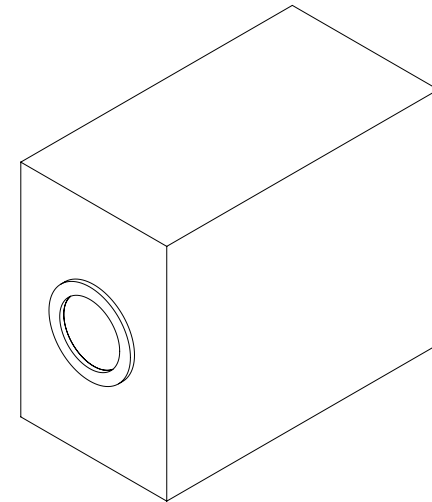

MODEL NUMBER	DESCRIPTION	COLOR
00406470	CAT6 CABLE ETHERNET UTP PLENUM JACKET	BLACK
00406471	CAT6 CABLE ETHERNET UTP PLENUM JACKET	BLUE
00406472	CAT6 CABLE ETHERNET UTP PLENUM JACKET	GREEN
00406473	CAT6 CABLE ETHERNET UTP PLENUM JACKET	GREY
00406474	CAT6 CABLE ETHERNET UTP PLENUM JACKET	RED
00406475	CAT6 CABLE ETHERNET UTP PLENUM JACKET	WHITE
00406476	CAT6 CABLE ETHERNET UTP PLENUM JACKET	YELLOW

THESE COMMODITIES, TECHNOLOGY OR SOFTWARE WERE EXPORTED FROM THE UNITED STATES IN ACCORDANCE WITH THE EXPORT ADMINISTRATION REGULATIONS. DIVERSION CONTRARY TO U.S. LAW PROHIBITED.

UNLESS OTHERWISE SPECIFIED LEADING DIMENSIONS ARE INCHES DIMENSIONS IN [] ARE MILLIMETERS

TOLERANCES:
 .X = ±.2 [.508] FRACTIONS
 .XX = ±.02 [.51] ± 1/32
 .XXX = ±.005 [.13] ANGLES ± 1°

CABLE LENGTH (L) TOLERANCES:
 L ≤ 12 [305] = +1 [25] / -0
 12 [305] < L ≤ 60 [1524] = +2 [51] / -0
 60 [1524] < L ≤ 120 [3048] = +4 [102] / -0
 120 [3048] < L ≤ 300 [7620] = +6 [152] / -0
 300 [7620] < L = +5%L / -0

ALL DIMENSIONS SHOWN ARE FOR REFERENCE ONLY.

NavePoint
 an INFINIT® brand

859 E. Park Avenue, Libertyville, IL 60048
 Phone: 1.800.505.1363
 Website: www.navepoint.com
 E-mail: sales@navepoint.com

SIZE	CAGE CODE	DRAWN BY	ITEM NO.	REV
A	7UTA6	MVEERAPPAN	00406470	A

THIRD-ANGLE PROJECTION

THE INFORMATION AND DESIGN IN THIS DOCUMENT IS THE PROPERTY OF TRANSECTOR, INC. ALL RIGHTS RESERVED.

SHEET 1 OF 1

SCALE N/A