

REVISIONS			
REV.	DESCRIPTION	DATE	APPROVED
A	INITIAL RELEASE	2/7/2022	WDIBELLA

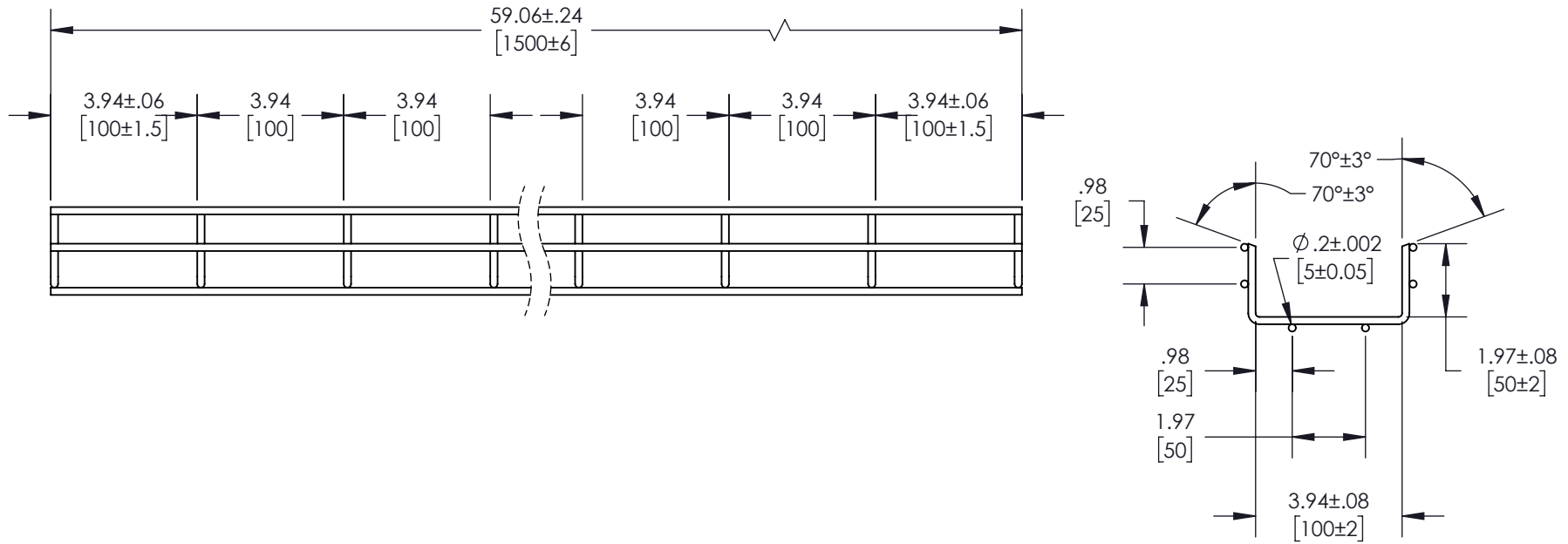

NOTES:

- ZINC PLATING THICKNESS: >12µm

THESE COMMODITIES, TECHNOLOGY OR SOFTWARE WERE EXPORTED FROM THE UNITED STATES IN ACCORDANCE WITH THE EXPORT ADMINISTRATION REGULATIONS. DIVERSION CONTRARY TO U.S. LAW PROHIBITED.

UNLESS OTHERWISE SPECIFIED
LEADING DIMENSIONS ARE INCHES
DIMENSIONS IN [] ARE MILLIMETERS

TOLERANCES:
 X = ± 2 [5.08] | FRACTIONS ± 1/32
 .XX = ± 0.02 [.51] | ANGLES ± 1°
 XXX = ± 0.005 [.13]

CABLE LENGTH (L) TOLERANCES:
 L ≤ 12 [305] = +1 [25] / -0
 12 [305] < L ≤ 60 [1524] = +2 [51] / -0
 60 [1524] < L ≤ 120 [3048] = +4 [102] / -0
 120 [3048] < L ≤ 300 [7620] = +6 [152] / -0
 300 [7620] < L = +5%L / -0

ALL DIMENSIONS SHOWN
ARE FOR REFERENCE ONLY.



an INFINIT® brand

859 E. Park Avenue, Libertyville, IL 60048

Phone: 1.800.505.1363

Website: www.navepoint.com

E-mail: sales@navepoint.com

THIRD-ANGLE PROJECTION

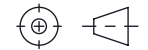

THE INFORMATION AND
DESIGN IN THIS DOCUMENT
IS THE PROPERTY OF
TRANSECTOR, INC.
ALL RIGHTS RESERVED.

SHEET 1 OF 1

SCALE N/A

SIZE A	CAGE CODE 7UTA6	DRAWN BY HBAKKE	ITEM NO. 00406763	REV A
-----------	--------------------	--------------------	----------------------	----------